

ORIGINAL ARTICLE

Standardization of the potentizing machine and quantification of impact of potentization

Rajesh Shah*

ABSTRACT

Introduction: Lack of accuracy and uniformity of impact have been the limitations of the ancient and current methods of potentization. Non-standardized electromechanical potentizers are in use across industry. It is very important that within each manufacturing process, the number of succussions should remain constant as well as the impact given (force exerted) is quantified. The author proposes to give importance to the force parameters in potentization and quantify the impact of potentization.

Materials and Methods: The author develops electromechanical potentizer with certain specifications such as arm length, weight, and angle at which the arm drops at the base. The machine was operated with specific instructions given in the machine operation manual. The force parameters were calculated and standardized.

Results: Torque is measured to quantify the impact of the force applied in potentization. The magnitude of torque is to be calculated by the force applied, length of the lever arm connecting the axis to the point of force application, and angle between the force vector and the lever arm.

In this case, torque was calculated to be = 40.43 Nm.

Since ten strokes are given, torque applied at every potency is calculated as 40.43.

Conclusion: Necessity for the documentation of force parameters used in the process of potentization has been identified, and a tool is developed to demonstrate it.

Keywords: Force, Homoeopathy, Impact, Potentization, Potentizer, Standardization, Succussion, Torque

INTRODUCTION

The unique process of preparing homoeopathic medicines is called potentization or drug dynamization, originally introduced by the founder Dr. Hahnemann around 1821. This process distinguishes Homoeopathy from other systems of medicine, which is also the backbone of the nature of the homoeopathic medicines and linked to the

Access this article online

Website:

www.ijrh.org

DOI:

10.4103/0974-7168.183879

Quick Response Code:



Director: Life Force Homeopathy,
Mumbai, Maharashtra, India

***Address for correspondence:**

Dr. Rajesh Shah,
Director and Research Head at
Life Force, 411-Krushal
Commercial Complex, GM Road,
Chembur, Mumbai - 400 089,
Maharashtra, India.
E-mail: sanjivak@gmail.com

Received: 15-03-2016

Accepted: 23-05-2016

This is an open access article distributed under the terms of the Creative Commons Attribution-NonCommercial-ShareAlike 3.0 License, which allows others to remix, tweak, and build upon the work non-commercially, as long as the author is credited and the new creations are licensed under the identical terms.

For reprints contact: reprints@medknow.com

How to cite this article: Shah R. Standardization of the potentizing machine and quantification of impact of potentization. Indian J Res Homoeopathy 2016;10:126-32.

homoeopathic philosophy, and in turn, drives the rules of the dose and repetition of the medicines. It is also possibly related to the recently recognized concept of homoeopathic medicines containing nanoparticles, where it is demonstrated that the size of the nanoparticles vary from potency to potency.^[1,2] Surprisingly, the process of potentization and the method of potentizing are not scientifically standardized.

Background

If we look back at the history of potentization, it must be noted that Dr. Hahnemann used very small dose of the tincture of *Quinine (Cinchona officinalis)* and subsequently *Belladonna* and other medicines and kept on reducing the quantity to a drop and then reduced it by further diluting it with water. To reduce the physiological effects of the dose, he continued the dilution and also used the route of vigorous shaking, which eventually turned into a systematic process of potentization or dynamization.

In 1814, he used vigorous shaking of the bottle containing the medicine substance and a vehicle for 3 min. In 1818, he did the trituration for the 1st time.^[3] In 1821, he concluded to do succussions by giving ten strokes to the bottle using the full strength of the arm.^[3] In 1825, Dr. Hahnemann began viewing homoeopathic medicines as dynamized or potentized as probably the dose became infinitesimal. In 1837, he continued with ten strokes process, presumably by hands.^[4,5]

Dr. Hahnemann had defined potentization as “This remarkable transformation of the properties of natural bodies through the mechanical action of trituration and succussion on their particles (while these particles are diffused in an inert dry or liquid substance) develops the latent dynamic powers previously imperceptible and as it were lying hidden asleep in them.”^[6] Strong shaking after every dilution is required to retain the activity of the original agent; photons are involved in the transmission of information, and photon-absorbing structures that reemit photons in specific ways are involved.^[7]

Dr. Hahnemann performed dynamization or potentization of medicines by a precise number of shakings (succussions) or strokes in given time sequences or by an exact number of triturations of the medicinal substance that was free from all coarse materials. Such high dilution was then potentized (dynamized) by repeated strokes.

Dr. Hahnemann used high potencies which he achieved by dynamizing with exact number of strokes.

Dr. Hahnemann said that the successive strokes against hard, elastic body to every vial containing one drop of the lower potency with 99 drops of alcohol (vehicle) to obtain strong potencies are vastly more effective than giving only a few nerveless successive strokes, which will produce little more than dilutions, which ought not to be the case.

Importance of Force Parameters

Potentization appears to be a process, which activates biological activity of the source material through physicochemical changes, generated by serial application of certain quantum of force. At this point, there is no adequate clarity about the nature of the exact change taking place through the process of potentization. However, what is computable is the quantum of applied force, which can be quantified and standardized for every medicine used for scientific experiment as well as for clinical application.

The essential component of potentization is to exert certain force on the medicinal substance mixed with vehicle. The force imparted might be producing disintegration or activation of the particles of the source material, about which we do not have clarity. The recent research has demonstrated the presence of nanoparticles^[1] observed in the potentized medicines, which are appearing to be resulting from the force exerted on the medicine vials. Another theory is about molecular imprint and ionization through the process of potentization. Scientists have conducted the experiments to measure the particle size of a few Homoeopathy medicines. A general mathematical expression of the form $y = ax^{-n}$ has been derived which relates the size of nanoparticles (y) with the corresponding potencies (x).^[8] The effect of potentization of the hydrophilic homoeopathic drug *Cuprum metallicum* on the phase profile of the liposomal membrane was studied by Ghosh *et al.*^[9] It can also logically be presumed that the activation of the therapeutic properties would depend on the amount of force the medicinal substance is exposed to, making it imperative that we measure and standardize the force applied to each medicine thus potentized.

In the earlier days, since the potentization was carried out by hands, the measurement and standardization of the force parameters were not possible. Since the current potentization technique entails use of machines, it is not only possible but also important to standardize and document the force parameters for every preparation.

Having realized that the force applied on each potentized medicinal preparation is the key factor determining its possible therapeutic efficacy, the author recognizes and emphasizes the need for incorporation of the force parameters in the homoeopathic pharmacopeia and also making the documentation of the same mandatory by the pharmaceutical industry. As on today, there is complete ignorance prevailing in this area.

Neglected Area

In spite of being in practice since 1816, the process of potentization has remained ill-defined, vague, empirical, and nonscientific as it is nonstandardized, having variations as many as the number of pharmaceutical companies. The literature shows variation in the number of strokes, from 10 to 100 strokes.

Risks in Handmade Potencies

Dr. Hahnemann began potentization by striking a vial containing homoeopathic medicinal substance on a larger, leather-bound book or *Bible*. Even today, several pharmacies happily claim that they use handmade potencies. Following risks and uncertainties must be noted:

1. The risk of variation in the force applied in the handmade potencies is extremely high.
2. Different persons striking the vial may have variable strength, leading to difference in force applied in the potencies thus prepared
3. As the volunteer keeps striking ten strokes per potency, amounting to 300, 2000, 10,000 strokes for 30C, 200C, 1000C, respectively, the strength could gradually reduce as human volunteers would tend to tire in such a laborious endeavor
4. Difficult monitoring (of number of strokes, power of striking) and hence poor reliability
5. Risk of breaking the vial, physical injury, and loss of medicine.

Uncertainties in Machine-made Potencies

The potentization machines were made by Benoit Mure (1838), Bernhardt Fincke (1868), Thomas

Skinner (1878) and others. However, the literature does not show any attempt to quantify the force parameters.

Most of the currently available potentized preparations are made using electromechanical potentizers. Following gaps need to be looked into:

1. The pharmacopeia does not recommend any specific potentizer. As a result, different companies use machines made with variable specifications
2. Different machines, obviously, apply different force on the medicines, which are not documented anywhere.
3. This situation results into possible variations in quality of the same medicine, prepared by different pharmacies. For instance, if you procure five vials of *Nux vomica* 30C from five pharmacies, it is likely that all of them may have undergone different amount of force exposures possible leading to distinct variation in their efficacy.
4. This calls for standardization of potentization. The standardization of potentizer across the world may take more time and efforts. However, it is easier to simply document on each preparation about the force applied using whichever machine used.

It is very important that in the manufacturing process, the number of succussions should remain constant as well as the impact given (force exerted) is quantified. Considering this need, the author has designed force parameters for an electromechanical potentizer which will impart the specific force, making the impact quantifiable.

Aims and Objectives

To establish the method of standardization of potentization machine parameters that will allow quantifying the impact.

MATERIALS AND METHODS

Machine parameters are suggested for standardization of the potentizer. A method is shown which will allow quantification of the impact of potentization, which can be applied and documented in any machine. Different machines may be having different documentable parameters. The author is urging on the need for documentation of the parameters.

The author has developed an electromechanical potentizer [Figure 1] with following specifications:

- Bottle holder with seven-bottle capacity (one dram glass bottle containing 3 ml liquid)
- Lid to lock the holder
- Stroke arm weighing 7.5 kg
- Arm length: 55 cm
- Angle at which arm drops from base level: 90°
- Digital display indicating number of strokes.

This machine can also hold 30 ml or 100 ml bottle, alternatively. In that case, the weight and the force parameters would be calculated accordingly. Any other parameter if used in any other machine must be specified to allow calculation of the applied force.

Machine is operated as per the following operation instructions:

Place the bottles containing the medicinal solution with specified proportion in bottle holder. Insert the lid and lock the arm. Start the machine to give ten strokes. Digital counter is attached to the machine to calculate number of strokes. The machine is driven by motor and the strokes given are continuous at the interval of 4.5 s, which is the time required to lift the arm to 90° and drop on hard material surface. Unlock the arm and remove the bottles once the strokes are given. Label and store the bottles appropriately.

RESULTS

Force parameter for the potentization machine^[10,11] is calculated as follows:

Weight (mass) of the arm = 7.5 kg

Length of arm = 55 cm = 0.55 m

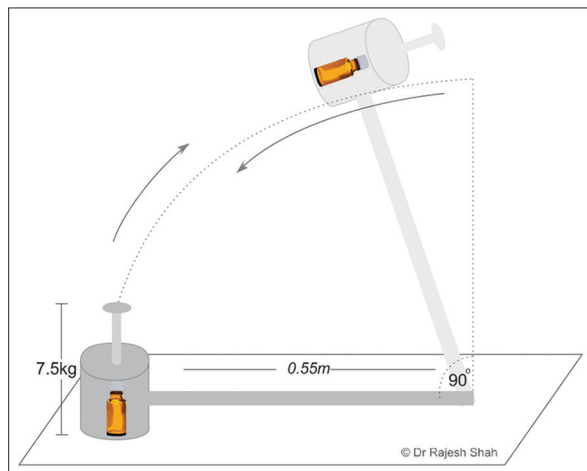

Figure 1: Potentization machine

Angle (θ) = 90°

The force (F) applied:

$$\begin{aligned} \text{Force} &= \text{weight} \times \text{gravitational acceleration} \\ &= 7.5 \text{ kg} \times 9.8 \quad = 73.5 \text{ N} \end{aligned}$$

Torque (τ), moment or moment of force (see the terminology below), is the tendency of force to rotate an object about an axis, fulcrum, or pivot.

The magnitude of torque depends on three factors: force applied, length of the lever arm connecting the axis to the point of force application, and angle between the force vector and the lever arm.

$$\text{Torque} = \tau = r \times F = |r| |F| \sin \theta.$$

where τ is the torque vector and $|\tau|$ is the magnitude of the torque, r is the displacement vector (a vector from the point from which torque is measured to the point where force is applied), $|r|$ is the length (or magnitude) of the lever arm vector, F is the force vector, and $|F|$ is the magnitude of the force. The angle θ is the angle between the position and force vectors. Here, the angle θ is 90° and $\sin 90^\circ$ is 1.

In this case: torque = 0.55 × 73.5 × 1 = 40.43 Nm.

Since ten strokes are given at every step of potentization, torque applied at every potency is calculated as 40.43 Nm × 10 = 404.3 Nm.

Similarly, since 30c potency would undergo 30 cycles of exposure to the above force, receiving 404.3 × 30 = 12,099 Nm, and likewise, 200c receives 80,860 Nm. Variations in the parameters would lead to difference in the total force accordingly.

DISCUSSION

Potentization is the only machine-based technology used in the system of Homoeopathy for preparing the medicines. The most vital factor in this process is the force, which is applied on the homoeopathic medicine resulting in the final outcome of the potentization, which seems to be responsible for the formation of the nanoparticles, important in developing the therapeutic efficacy of the source material. Surprisingly, this aspect has been completely overlooked and ignored by the profession since its inception.

There is an existing ambiguity about the nature of homoeopathic medicine due to its ultra-high

dilution. In addition, lack of documented information on the force exerted through the process of potentization makes it all the more weak in terms of its authenticity as a therapeutic agent. The only measurable parameter is the force used in the process.

It must be noted that due to lack of regulation, the homoeopathic medicine procured from the market does not give any information about the origin source material, if prepared from back-potency, information about the origin of back-potency, when was it prepared at the first place, the method of preparation (multi-vial or single-vial; Korsakovian, others), handmade or machine made, and the quantum of force used in potentization.

The author's proposal of documentation and incorporation of force parameters in the process of potentization needs to be considered by the profession and the concerned policymakers, which will help bring more scientific reliability to Homoeopathy. If the medicine is sourced from back-potency from certain pharmacy (without information of the machine parameters), it must be stated accordingly. There is a need to have clear specifications of the force parameters printed on the medicine bottle. Until the standard force parameters come in practice, the practitioners should be provided the information about the force applied on every medicine product available in the market. Similarly, for all new medicine provings (homoeopathic pathogenetic trials), it would be desirable if these parameters are documented. The author's suggestion of future homoeopathic medicine bottle content including information on the amount of force used and the method used in the potentization has been conceptualized in the graphic on this page [Figure 2].

Currently, the effect of force of potentization on the development of nanoparticles or on physical, chemical, and biological activities of homoeopathic

dilutions is not known. Future research may be carried out to examine effects of different force factors on quantity or quality of nanoparticles or some other elements developed in the process and also their effects thereof.

Using these specified force parameters, the author has developed HIV nosode,^[12] hepatitis C nosode,^[13] Hydroquinone, Capsaicin alkaloids, and *Mycobacterium tuberculosis* nosode.^[10,14,15]

CONCLUSION

Necessity for the documentation of force parameters used in the process of potentization has been identified and emphasized with an example of newly developed potentizer with specific considerations. Attention of the research organizations, policymakers, pharmaceutical industry, and the practitioners is drawn to the vital aspect of force parameters.

Acknowledgment

The author extends deep gratitude to the faculty of the Department of Mechanical Engineering at Indian Institute of Technology, Mumbai, for help in developing the basic potentizer which eventually was upgraded to an electromechanical tool with the help of Mr. Panchal and his team.

Financial Support and Sponsorship

Nil.

Conflicts of Interest

There are no conflicts of interest.

REFERENCES

1. A Fundamental Research Revealing the Hidden Secrets of Homeopathic Potencies, Homeobook. Available from: <http://www.homeobook.com/a-fundamental-research-revealing-the-hidden-secrets-of-homeopathic-potencies/>. [Last cited on 2016 Mar 02].
2. Chikramane PS, Suresh AK, Bellare JR, Kane SG. Extreme homeopathic dilutions retain starting materials: A nanoparticulate perspective. *Homeopathy* 2010;99:231-42.
3. Schmidt J. History and relevance of the 6th edition of the organon of medicine (1842). *Simile, Br Homeopath J* 1994;83:42-8.
4. Hahnemann S. *The Chronic Diseases, Their Peculiar Nature and Their Homeopathic Cure*. Vol. 1., New Delhi, B. Jain Publishers; p. 157.
5. Gysper H. The making of high potencies 1830-1930. *Am J Homeopath Med* 2013;106:47-61.
6. Hahnemann S. *Organon of Medicine*. Reprint. 6th ed. Delhi: B Jain publication; 1981. p. 288-90.
7. Czerlinski G, Ypma T. Domains of water molecules provide mechanisms of potentization in homeopathy. *Water* 2010;2:1-14.
8. Kar S, Bandyopadhyay P, Chakraborty S, Chakrabarty S, Paul BK, Ghosh S, *et al*. Derivation of an empirical relation between the size of the nanoparticle and the potency of homeopathic medicines. *Int J High Dilution Res* 2015;14:2-7.
9. Nandy P. A review of basic research on homoeopathy from a

Arnica montana 30C
(T= 68,761 Nm)
From Back-potency 29c (B&T), 1.1.1945
29C to 200C: 8th March 2016
Information on force parameters: Nil
Potentization Method: Korsakovian

Figure 2: Label - *Arnica*

Shah: Standardization of the quantification parameters of potentizing machine

- physicist's point of view. Indian J Res Homoeopathy 2015;9:3.p. 141-151. Available from: www.ijrh.org/temp/IndianJResHomeopathy93141-2166098_060100.pdf. [Last cited on 2016 Mar 14].
10. Shah R. Scientific method of preparing homeopathic nosodes. Indian J Res Homoeopathy 2014;8:166-74. Available from: <http://www.ijrh.org/text.asp?2014/8/3/166/141740>. [Last cited on 2014 Oct 21].
 11. Shah R. Hydroquinone: Homoeopathy pathogenetic trial. Indian J Res Homoeopathy 2013;7:2.
 12. Shah R. HIV nosode: The homeopathic pathogenetic trial. Forsch Komplementmed 2015;22:156-62.
 13. Shah R. Hepatitis C nosode: The preparation and homeopathic pathogenetic trial. Homeopathy 2013;102:207-14.
 14. Shah R. Effect of orally administered potentized capsaicin and dihydrocapsaicin in humans: A homeopathic pathogenetic trial. Forsch Komplementmed 2014;21:172-7.
 15. Joshi S, Mukerjee S, Vaidya S, Talele G, Chowdhary A, Shah R. Preparation, standardization and *in vitro* safety testing of Mycobacterium nosodes (Emtact-polyvalent nosode). Homeopathy. 131.

पोटेंटाइजिंग मशीन का मानकीकरण एवं पोटेंटाइजेशन के प्रभाव की मात्रा का माप

परिचय: होम्योपैथिक औषधियों को तैयार करने की तकनीक हाथ से बनाने के बजाय अब मशीनीकृत प्रक्रिया में बदल गई है। शुद्धता की कमी और प्रभावों में अनियमितता प्राचीन और वर्तमान पद्धतियों की सीमाएं रहीं हैं। गैर मानकीकृत इलैक्ट्रोमैकेनिकल पोटेंटाइजर पूरे उद्योग में प्रयोग किए जाते हैं। यह बहुत ही महत्वपूर्ण है कि हर निर्माण प्रक्रिया में सक्कशन की मांग स्थाई रहनी चाहिए और दिए गए प्रभाव परिमाणात्मक होने चाहिए। इस आवश्यकता को ध्यान में रखते हुए लेखक ने पोटेंटाइजेशन में बल मानकों को महत्व देने का सुझाव दिया है।

पद्धति: लेखक ने कुछ विशेषताओं के संग इलैक्ट्रो मैकेनिकल पोटेंटाइजर को विकसित किया है जैसे बाजू की लंबाई, वजन और जिस कोण पर बाजू बेस पर गिरेगी। मशीन का परिचालन मशीन पुस्तिका में संग दिए गए निर्देशों के अनुसार किया जाएगा। बल मानकों को गिना और मानकीकृत किया गया।

परिणाम: परिणाम को टॉर्क के अनुसार मापा गया। लागू किए गये बल के आधार पर टार्क के परिमाण, बल लगाने के केंद्र से धुरी को लीवर हाथ की लंबाई से जोड़ने और बल वेक्टर और लीवर हाथ के बीच कोण की गणना की गई।

इस मामले में चूंकि दस स्ट्रोक दिए गए हैं, हर क्षमता पर लागू टॉर्क की गणना $40.43 \text{ Nm} \times 10 = 404.3 \text{ Nm}$ के रूप में की गई है।

निष्कर्ष: पोटेंटाइजेशन की प्रक्रिया में प्रयुक्त बल पैरामीटरों के दस्तावेजों के लिए आवश्यकता की पहचान कर ली गई है और एक नए पोटेंटाइजर को विकसित किया गया है।

Estandarización de la máquina de potenciación y cuantificación del impacto de potenciación

RESUMEN

Introducción: Las limitaciones de los métodos antiguos y actuales han sido la falta de precisión y de uniformidad del impacto. En la industria, se utilizan potenciadores electromecánicos no estandarizados. Es muy importante que en cada proceso de fabricación el número de succiones se mantenga constante y que se cuantifique el impacto (fuerza ejercida). El autor propone dar importancia a los parámetros de fuerza en la potenciación y cuantificar el impacto de la potenciación.

Método: El autor desarrolla un potenciador electromecánico con determinadas especificaciones como la longitud del brazo, el peso y el ángulo con el que el brazo golpea la base. La máquina funciona según determinadas instrucciones especificadas en el manual operativo de la máquina. Los parámetros de fuerza se han calculado y estandarizado.

Resultados: El impacto se mide en términos de torque. Se calculó la magnitud del torque que depende de la fuerza aplicada, la longitud del brazo de palanca que conecta el eje con el punto de aplicación de la fuerza y el ángulo entre el vector de fuerza y el brazo de palanca.

En este caso: Torque = 40,43 Nm (Newton metro)

Dado que se indican 10 golpes, el torque aplicado en cada potencia se calcula como 404,3 Nm.

Conclusiones: Se ha identificado la necesidad de documentar los parámetros de fuerza en el proceso de potenciación y se ha desarrollado una herramienta para demostrarlo.